

(No Model.)

G. F. BALLOU.

WORK HOLDER FOR LATHES.

No. 359,379.

Patented Mar. 15, 1887.

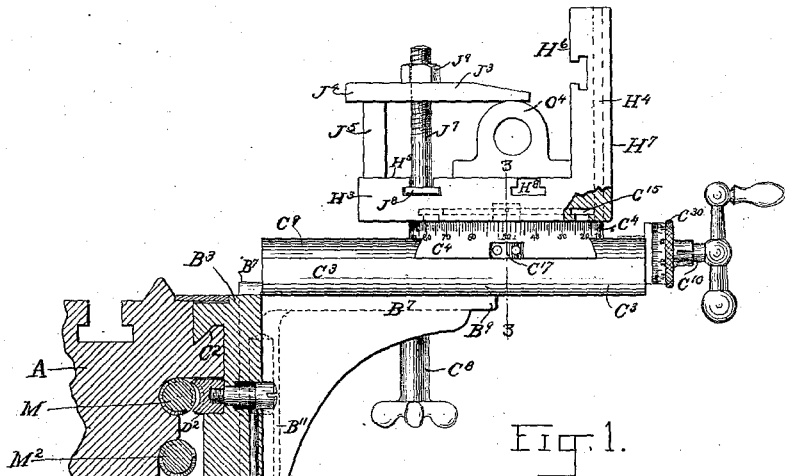

Fig. 1.

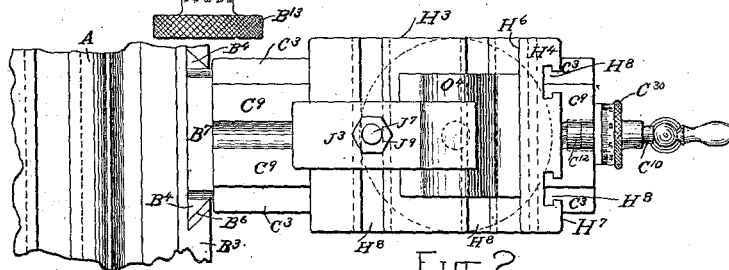

Fig. 2

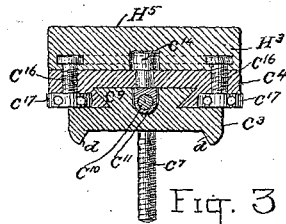

Fig. 3

WITNESSES.

John F. Nelson.

Kate E. Bellows.

INVENTOR.
George F. Ballou
by his Attorneys
Brown Bros

UNITED STATES PATENT OFFICE.

GEORGE F. BALLOU, OF WALTHAM, MASSACHUSETTS.

WORK-HOLDER FOR LATHES.

SPECIFICATION forming part of Letters Patent No. 359,379, dated March 15, 1887.

Application filed June 9, 1886. Serial No. 204,623. (No model.)

To all whom it may concern:

Be it known that I, GEORGE F. BALLOU, of Waltham, in the county of Middlesex and State of Massachusetts, have invented certain new and useful Improvements in Work-Holders for Slide-Lathes, of which the following is a full, clear, and exact description.

The work-holder of this invention is more particularly designed and intended for use in slide-lathes of the general construction and arrangement of parts, including the slide-rest and slide-carriage fully shown and described in a separate application for Letters Patent of the United States of even date herewith, filed June 9, 1886, Serial No. 204,623; but, as will be obvious from the description hereinafter given, this holder is adapted to be used in slide-lathes and with slide-rests and slide-carriages of other constructions and arrangements of parts.

This invention, in substance, consists, first, of a holder to be used in slide-lathes for holding and securing work to be operated upon in the slide-lathe—as, for instance, to be drilled, milled, &c.—composed of a frame having two lengths or arms meeting at an angle, preferably a right angle, and the inner meeting faces of such lengths each adapted in any suitable manner for the engagement therewith of means suitable to clamp work thereto; second, of a holder to be used in slide-lathes for holding and securing work to be operated upon in the slide-lathe—as, for instance, to be drilled, bored, milled, &c.—composed of a frame having two lengths or arms meeting at an angle, preferably a right angle, and the inner meeting faces of such lengths and also the outer face of one of the lengths severally adapted in any suitable manner for the engagement therewith of means suitable to clamp work thereto; third, of a holder to be used in slide-lathes for holding and securing work to be operated upon in the slide-lathe—as, for instance, to be drilled, bored, milled, &c.—composed of a frame having two lengths or arms meeting at an angle, preferably a right angle, and the so meeting faces of such lengths each adapted in any suitable manner for the engagement therewith of means suitable to clamp work thereto, in combination with a slide-rest of a slide-lathe made in separate parts, or slides constructed and

applied together to be moved and adjusted upon each other in parallel and rectilinear planes and directions, and as a whole adapted to be secured to the lathe bed or shears, and preferably for adjustment longitudinally, vertically, and horizontally thereon, and having said holder attached to one and the upper of its slides to be swung and adjusted thereon in a curvilinear and horizontal direction, and, so swung and adjusted, fastened against movement.

In the drawings forming a part of this specification a work-holder of this invention and its combination with the slide-rest and slide-carriage before referred to are illustrated.

Figure 1 is a transverse vertical section of the lathe-bed broken away, and a view in elevation of the work-holder of this invention and of the slide-rest and slide-carriage from the head-stock end of the lathe, the head and tail stocks being removed. Fig. 2 is a plan view of the parts as shown in Fig. 1. Fig. 3 is a vertical section on line 3 3, Fig. 1.

In the drawings, A represents the lathe bed or shears of a slide-lathe. The slide-lathe in any and all respects, except as to the features of this invention hereinafter described, may be of any of the ordinary and well-known constructions and arrangements of slide-lathes; but a slide-lathe and a slide-carriage and a slide-rest therefor all such as shown and described in the application stated are most preferable, and which, so far as necessary for this invention, are shown and will be herein described, it not being thought necessary to fully illustrate the other parts thereof, as they in no particular form any part of the present invention.

M M² are the upper and lower leading-screws of the slide-lathe referred to. The upper leading-screw, M, and also the lower leading-screw, M², are connected and rotated from the rotation of the lathe-arbor and otherwise, as described in said application.

The rotation of the leading-screws is for the purpose of moving a slide-carriage lengthwise along the front cheek of the lathe bed or shears, and which carriage is suitably constructed therefor, and the upper leading-screw, M, which is for fine work, connects with horizontal sectional or half screw-nuts D² (one only shown,

but two being preferable) of the slide-carriage, and the lower leading-screw, M², which is for general work, connects with the slide-carriage by mechanism consisting, among other parts, of a hand-wheel, (not shown,) and otherwise all as fully described and shown in the application aforesaid, and the whole such as to enable the slide-carriage to be moved lengthwise of the lathe-bed in either direction, and either from the action of the driving mechanism of the lathe or by the hand-wheel, and also to enable the speed of such movement to be varied and adjusted and either of the leading-screws to be brought into action upon the slide-carriage, and all as is fully shown and set forth in the application aforesaid. These several parts and their combination and arrangement, as above referred to, form of themselves no part of this invention, and so it is not deemed necessary to herein further describe them.

The slide-carriage is in two parts, to wit: a vertical plate or block, B³, with a front flat face and a back face of angular shape to fit a corresponding angular-shaped guideway, C², thereof of the front cheek of the lathe-bed, and a bracket with an upright portion, B⁴, arranged to move vertically in a dovetail way, B⁶, of the front face of the block B³, and a horizontal arm, B⁷, which projects from the upper end of said upright B⁴ and at right angles to the length of the slide-carriage, and is made of fork shape, and preferably with the space between its tines open at the front end, B².

The bracket B⁴ B⁷ is vertically adjustable on the slide-carriage through the turning of a vertical screw-rod, B¹⁰, engaging with the vertical screw-nut portion B¹¹ of the bracket and turning loosely within a horizontal bearing-block, B¹², of the slide-carriage, and therein confined against lengthwise movement in any suitable manner. This screw-rod B¹⁰, by which to adjust the bracket B⁴ B⁷ vertically, as above stated, has at its lower end a milled head, B¹³, peripherally and properly graduated in one hundred equal parts or divisions, each representing a one-thousandth of an inch, and figured for the rise and fall of the bracket from the turning of said screw to be measured and determined in one-thousandth parts of an inch, using a suitable index-mark at the front side of the bearing-block B¹² of the screw-rod.

The vertically-adjustable bracket B⁴ B⁷ of slide-carriage supports and carries a slide-rest in two horizontal parts or slides, C³ and C⁴, placed upon each other. Slide C³—the lower slide of the two slides of the slide-rest—is made with flaring edges d, which fit and set over corresponding flaring edges of the bracket-table B⁷. The direction of these flaring edges transversely to the width of the bracket-table B⁷, and as shown, is preferably such as to permit slide C³ to be set bodily upon the bracket-table B⁷ without requiring it to be slid lengthwise along the same, and otherwise all arranged for slide C³, with all the other parts connected with it, to be moved horizontally on the table

B⁷ forward to and backward from the axial line of the lathe-arbor. (Not shown.)

C⁷ is a screw-bolt projecting downward from slide C³ of slide-rest and between the tines of the forked table B⁷, and C⁸ is a screw or thumb nut screwing on said bolt and fastening said slide C³ to table B⁷ and against movement thereon. Slide C⁴ of the slide-rest fits by a dovetail way in its under side over a corresponding dovetail projection, C², on the upper side of the lower slide, C³, and thus slides C³ C⁴ are adapted for a movement of the upper slide on the lower slide of the two and in a horizontal plane, and one parallel with and in the direction of the horizontal slide of the lower slide, C³, on bracket B⁴ B⁷. Slide C⁴ has a circular and vertical edge marked off or graduated in representation of the degrees of a circle, Fig. 1, and it is provided with a horizontal screw-rod, C¹⁰, which engages with a screw-nut, C¹¹, and by peripheral collar and groove (not shown) is engaged with the bearing-block C¹², and thus screw-rod C¹⁰, when turned, is confined against lengthwise movement through said block.

C¹⁰ is a milled head of screw C¹⁰. This head is peripherally graduated in one hundred equal parts, each, using a suitably-located index-mark as a guide, representing in the movement of the slide operated by the screw-rod a one-thousandth part of an inch.

H³ H⁴ is the angular frame making the work-holder of this invention. This frame is in two lengths or arms, H³ H⁴, having inner faces, H⁵ H⁶, respectively, meeting at an angle, preferably a right angle. The length or arm H³ makes the base of the holder, and it sets upon the upper slide, C⁴, of the slide-rest, and in width it corresponds to the diameter of the graduated circular rim or edge of such slide, and it is arranged to swing around a vertical central pintle, C¹⁴, thereof, and using a suitable index-mark, Fig. 1, of its edge, with the graduations of the circular edge of slide C⁴. The work-holder can thus be adjusted definitely in a curvilinear direction and the work secured thereon, as hereinafter described, placed in any angular direction desired in relation to the rectilinear movements of the parts of the slide-rest on each other, and of the slide-rest as a whole on the slide-carriage, and the slide-carriage with the slide-rest on the lathe-bed. The base-arm H³ of the work-holder frame has a curvilinear running groove, C¹⁵, of T shape in cross-section, and concentric with the axis of swing of the holder around the central pintle, C¹⁴, of slide-rest, and C¹⁶ are bolts at opposite diametrical points and engaged by their T-shaped heads with said T-shaped groove. These bolts pass loosely through the thickness of rest-slide C⁴, and on the under side of the slide each bolt receives a screw-nut, C¹⁷. Tightening the screw-nuts C¹⁷ fastens the holder to and loosening them releases the holder from slide-rest, leaving it free to be swung around on the same.

Each of the inner meeting faces, $H^5 H^6$, of the holder, and also the outer vertical face, H^7 , of the upright leg H^4 of the holder, and which face is parallel with the vertical face H^3 of the meeting faces $H^5 H^6$, is provided with a series of parallel grooves, H^8 , each T-shaped in cross-section. The grooves of the meeting faces $H^5 H^6$ are horizontal, and those of the outer vertical face, H^7 , are vertical. These several grooved faces $H^5 H^6 H^7$ are the work-holding faces of the holder, and the work to be held placed upon the proper face of the holder is then firmly secured to it with any suitable clamping means, using a groove or grooves H^8 of the holding face or faces of the holder for engaging such means with and securing them to the holder. One form of and a suitable clamping mechanism is shown, and it consists of a horizontal arm, J^3 , supported at one end, J^4 , on a post, J^5 , and at the other end resting upon and confining and clamping the work O^1 . This arm or jaw J^3 , between its ends, is connected to the work-holder of this invention by a vertical screw-threaded bolt, J^7 , having its head J^8 entered into a T-shaped groove H^9 of the upper and inner face, H^5 , of the base-arm H^2 of the work-holder, and the whole is then secured and firmly bound together by means of a screw-nut, J^9 , screwed upon the screw-bolt and brought to a seat against the upper edge or side of the horizontal arm or jaw J^3 .

The piece of work O^1 , shown as clamped to the horizontal face H^5 of the holder, as above explained, obviously could be clamped, using the clamping means described, as well to either of the vertical faces $H^6 H^7$.

In the practical use of the work-holder, and with it attached to a slide-rest and the slide-rest to a slide-carriage, and it in turn to the lathe-bed, all substantially as has been described, plainly work secured to the holder as described, or in any other suitable way, can be presented practically in any and all horizontal directions and angles, each presentation being independent of the others.

The work-holder herein described is most particularly applicable to the slide-lathe, slide-rest, and slide-carriage herein referred to; but it is not intended to be limited thereto.

Again, the work-holder of this invention is most serviceable as a means of holding work for being drilled, bored, milled, and otherwise operated upon in a slide-lathe, and it is most particularly adapted for use with the vertical drilling fixture making the subject of separate applications for Letters Patent of the United States of even date herewith.

Having thus described my invention, what I claim, and desire to secure by Letters Patent, 60 is—

1. A holder for use in a slide-lathe to hold work, composed of a frame in two lengths meeting at an angle, and the meeting faces of each length constructed to receive and fasten means for clamping work thereto, and for a rectilinear adjustment of such means, substantially as described, for the purpose specified. 65

2. A holder for use in a slide-lathe to hold work, composed of a frame in two lengths meeting at an angle, and the meeting faces of each length constructed to receive and fasten means for clamping work thereto, and of slides in separate parts constructed and applied together to be moved and adjusted one upon the other in parallel and rectilinear planes and directions, and having said frame connected thereto and arranged to swing thereon, substantially as described, for the purpose specified. 70 75

3. A holder for use in a slide-lathe to hold work, composed of a frame in two lengths, $H^3 H^4$, having faces $H^5 H^6$, meeting at an angle, and each face provided with grooves H^8 for receiving and securing work-clamping devices, substantially as described, for the purpose specified. 80

4. A holder for use in a slide-lathe to hold work, composed of a frame in two lengths, $H^3 H^4$, having faces $H^5 H^6 H^7$, and each face provided with grooves H^8 for receiving and securing work-clamping devices, substantially as described, for the purpose specified. 85 90

In testimony whereof I have hereunto set my hand in the presence of two subscribing witnesses. 95

GEO. F. BALLOU.

Witnesses:

ALBERT W. BROWN,
FRANCES M. BROWN.